

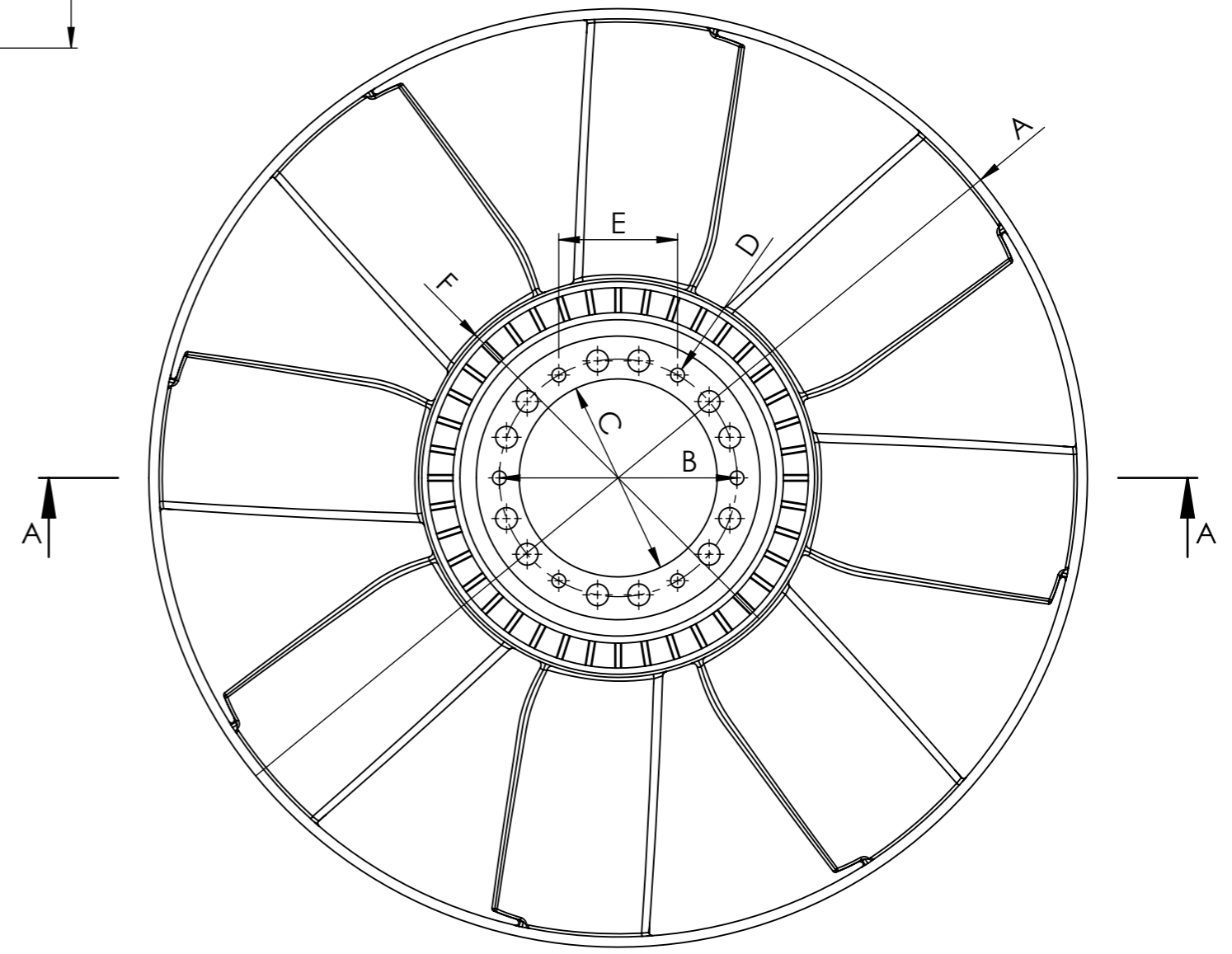

SECTION A-A

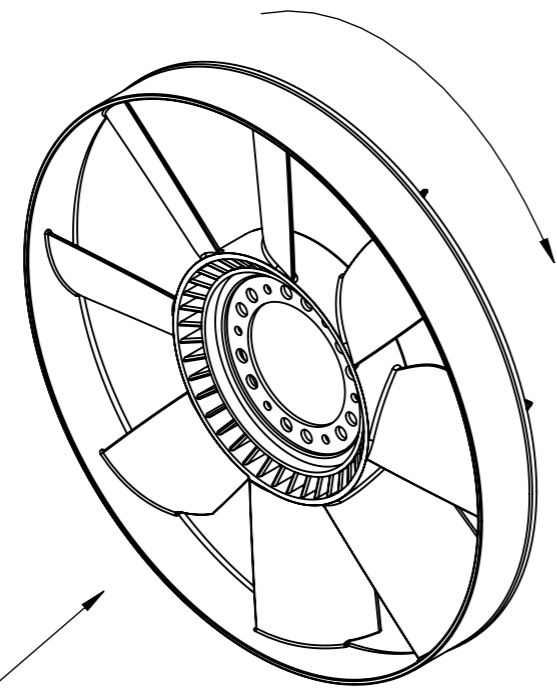

| Dimensional values | | FAN WHEEL | | | |
|--------------------|-----------------------|-----------|-----------------------|----|--|
| Ref.n° | Value | Ref.n° | Value | | |
| A | $\phi 600 \pm 3$ mm | G | 59 ± 3 mm | | |
| B | $\phi 152,4$ mm | H | 35 ± 3 mm | | |
| C | $\phi 127 +0,30$ mm | I | $92,3 \pm 3$ mm | | |
| D | 6x $\phi 9$ mm | J | $\phi 592,5 \pm 3$ mm | | |
| E | 76.2 mm | | | | |
| F | $\phi 248,5 \pm 3$ mm | | | | |
| Number of blades | | 8 | Configuration | CW | |

| Modification n° | Modified | Date | Reason |
|-----------------|----------|------|--------|
| 4 | | | |
| 3 | | | |
| 2 | | | |
| 1 | | | |

| Comments | | | |
|----------|--|--|--|
| | | | |

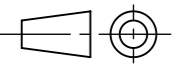
| | | | |
|--------------------------|---|---|------------------|
| Drawn |  | | |
| 28/04/21 V.P. | | | |
| Checked | | | |
| 28/04/21 R.U. | | | |
| General Tolerance | ISO 2768 c-K | Assembly Part name | Technical sheet |
| Material | | ID. Reference | Fan wheel |
| Scale: | 1/4 | Review: | 0 |
| | |  | Sheet 1/1 |