

1

2

3

4

A

Technical data / Datos técnicos:

A

Operating pressure / Presión de trabajo	max. 10 bar
Supply pressure / Presión de alimentación	max. 22 bar
Predominance / Predominancia	max. 0.2 bar
Permissible medium / Medio de funcionamiento	Air / Aire
Weight / Peso	900 gr

B

B

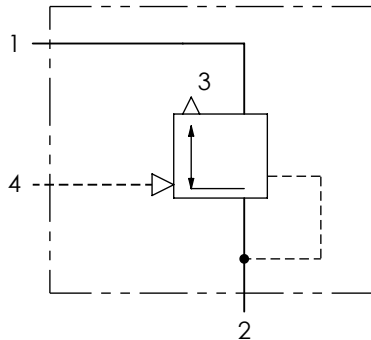

Port / Conexión	Function / Función	Thread / Rosca
1	Supply / Alimentación	M22x1.5
2	Delivery / Salida	2x M22x1.5
3	Exhaust / Escape	-
4	Control / Pilotaje	M22x1.5

C

C

D

D

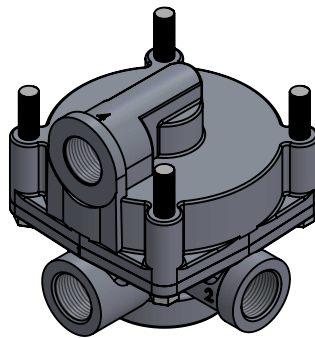

Purpose / Propósito: To rapidly supply and evacuate compressed air from pneumatic equipment and to reduce response times in pneumatic braking systems. / Suministrar y evacuar rápidamente aire comprimido de equipos neumáticos y reducir el tiempo de respuesta de estos equipos.

Installation requirements / Requisitos para la instalación: Mounting is accomplished using, at least, two of four M8 mounting bolts. The valve must be installed with exhaust pointing downwards. / El montaje se realiza mediante, al menos, dos de los cuatro pernos de montaje M8. La válvula debe montarse con el escape apuntando hacia abajo.

E

E

F

F

Modification	4				Drawn		
	3				17/02/11 A.U.		
	2				Checked		
	1	S.S.	17/09/25	Format update	17/02/11 A.L.		
Comments	nº	Modified	Date	Reason	General Tolerance	Assembly	-
					-	Part name	Relay valve
					Material	ID. Reference	2226401
				-	Scale: -		Sheet 1/2
				-	Review: 1		

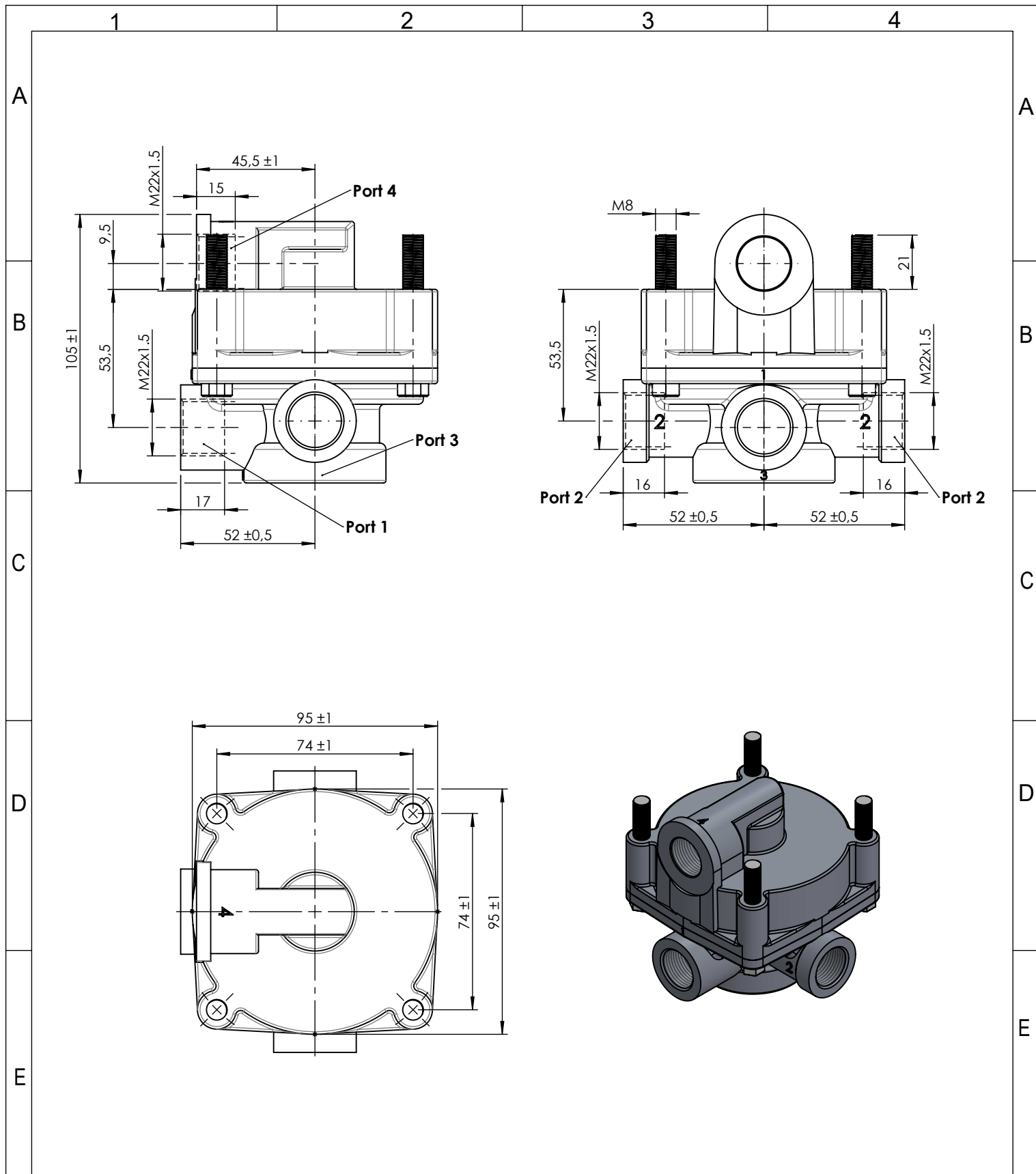

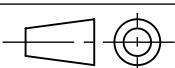
F	Modification	4				Drawn		F
		3				17/02/11 A.U.		
		2				Checked		
		1	S.S.	17/09/25	Format update	17/02/11 A.L.		
		n°	Modified	Date	Reason	General Tolerance		
	Comments				ISO 2768 c-K	Part name	Relay valve	
					Material	ID. Reference	2226401	
					-	Scale: 1/2		Sheet 2/2
					-	Review: 1		