

Technical sheet / Datos técnicos:

Part number adaptable to / Referencia adaptable a	0500005001
Operating pressure / Presión de trabajo	max. 12 bar
Max. working range / Rango máximo de trabajo	+/- 45°
Permissible medium / Medio de funcionamiento	Air / Aire
Operating temperature range / Rango de temperatura	-40 °C to / a +80 °C
Weight / Peso	500 gr

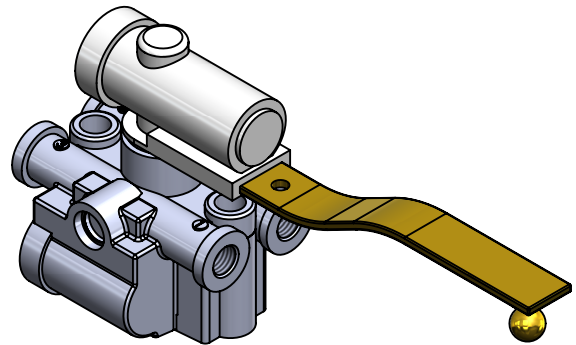
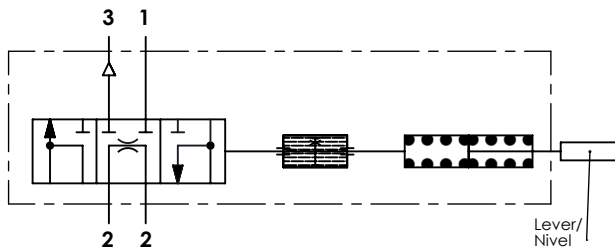

Port / Conexión	Function / Función	Thread / Rosca
1	Supply / Alimentación	M12x1.5
2	Delivery / Salida	2x M12x1.5
3	Exhaust / Escape	M12x1.5

Purpose / Propósito: The levelling valve controls the aire suspension bellows responsible for driving comfort. / La válvula niveladora controla el aire en suspensión responsable del confort para la conducción.

Installation requirements / Requisitos para la instalación: The levelling valve is fastened to the chasis on the right side of the truck by means of two bolts M8. To simplify the installation and the adjustment of the lever and the connecting linkage, the unit can be locked into its neutral position. / La válvula niveladora se sujetará al chasis del lado derecho del camión por medio de dos tornillos M8. Para facilitar su montaje, la varilla puede colocarse en su posición neutral.

Modification	4				Drawn		
	3				17/02/11 A.U.		
	2				Checked		
	1				17/02/11 A.L.		
	nº	Modified	Date	Reason	General Tolerance		Assembly
Comments					-	Part name	Leveling valve
					Material	ID. Reference	2314101
					-	Scale: -	
					-	Review: 0	

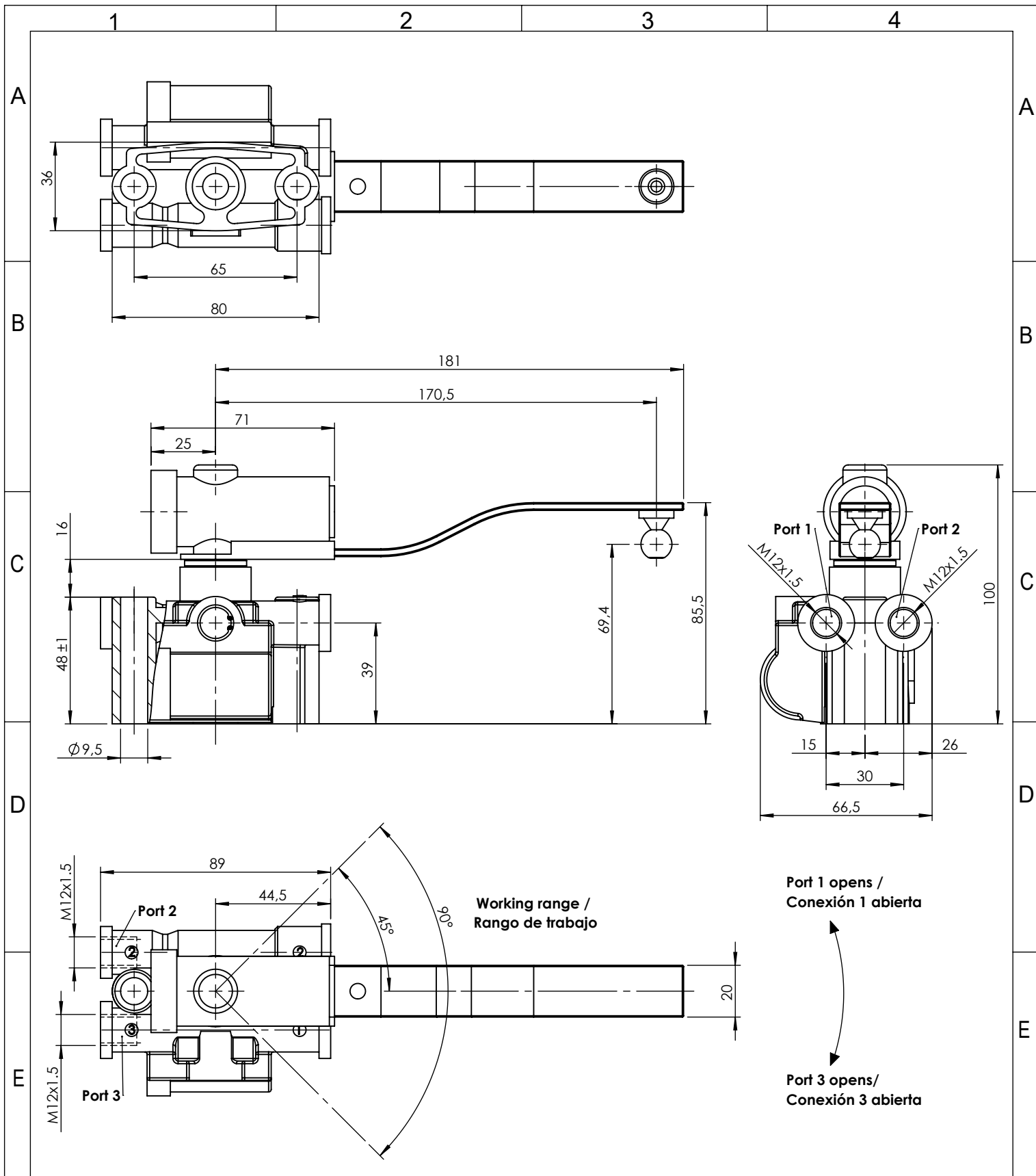

F	Modification	4				Drawn		F
		3				17/02/11 A.U.		
		2				Checked		
		1				17/02/11 A.L.		
	nº	Modified	Date	Reason	General Tolerance	Assembly	-	
Comments					ISO 2768 c-K	Part name	Leveling valve	
					Material	ID. Reference	2314101	
					-	Scale: 1/2		Sheet 2/2
					-	Review: 0		