

A

**Technical sheet / Datos técnicos:**

Part number adaptable to / Referencia adaptable a	9753034490
Opening pressure of safety valve / Presión de apertura válvula de seguridad	12 bar
Cut-out pressure / Presión de corte	7,3 ± 0,2 bar
Permissible medium / Medio de funcionamiento	Air / Aire
Operating temperature range / Rango de temperatura	-40 °C to / a +80 °C
Weight / Peso	650 gr

B

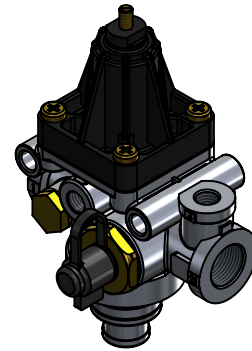
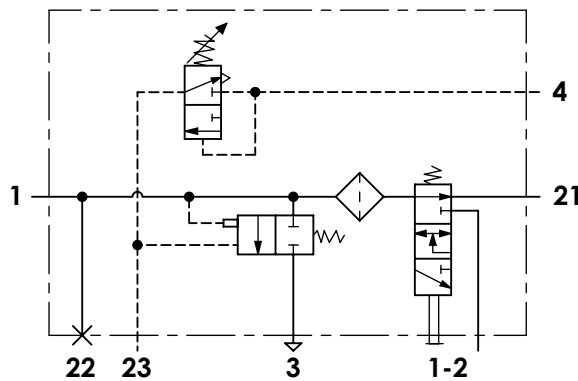

C

Port / Conexión	Function / Función	Thread / Rosca
1	Supply from air compressor / Alimentación desde el compresor	M22x1,5
1-2	Tire inflation device / Dispositivo de inflado de neumáticos	M16x1,5
21	Delivery to air dryer / Salida al secador	M22x1,5
22	Auxiliary supply / Alimentación auxiliar	Closed / Taponada
23	Control to air dryer / Pilotaje al secador	M12x1,5
4	Control / Pilotaje	M12x1,5
3	Exhaust / Escape	-

D

**Purpose / Propósito:**

Regulation of air pressure in the air reservoirs. When air reservoirs reach enough pressure, send a signal to the air dryer to start with the regeneration phase and the filter cleaning./

Regulación de la presión de aire en los depósitos de aire comprimido. Cuando los depósitos de aire comprimido tienen una presión suficiente, manda una señal a la válvula secadora para empezar con la etapa de regeneración y limpieza del filtro.

E

**Installation requirements / Requisitos para la instalación:**

The unloader valve should be installed so that the exhaust port points downwards. Mounting is accomplished with two M8 screws. / El regulador debe instalarse de forma que el escape quede orientado hacia abajo. El montaje se realiza con dos tornillos M8.

F

Modification	4				Drawn		
	3				05/08/14 A.U.		
	2				Checked		
	1				05/08/14 A.L.		
Comments	nº	Modified	Date	Reason	General Tolerance	Assembly	
						-	Part name
						-	ID. Reference
						-	2228231
					Scale: -		
					Review: 0		Sheet 1/2

1 2 3 4

A

A

B

B

C

C

D

D

E

E

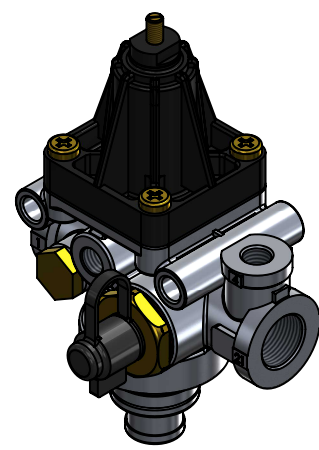
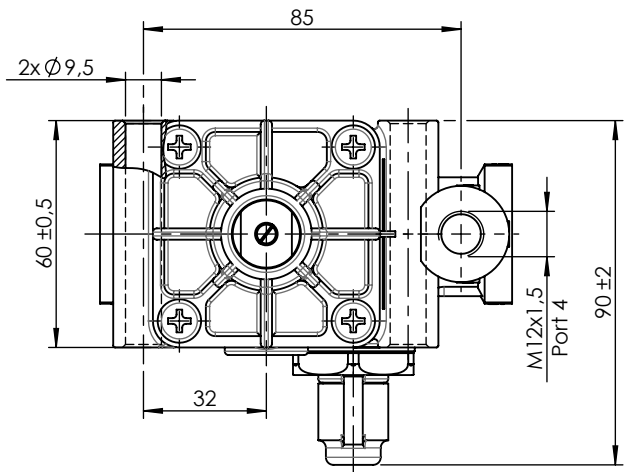
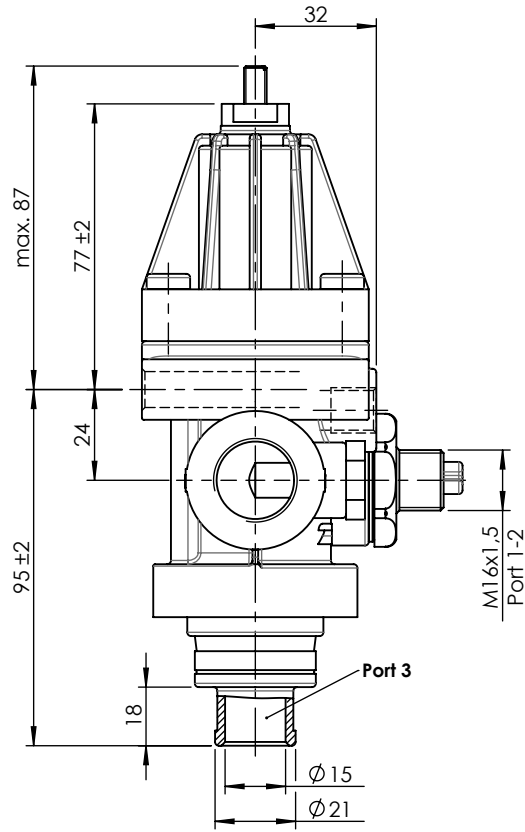
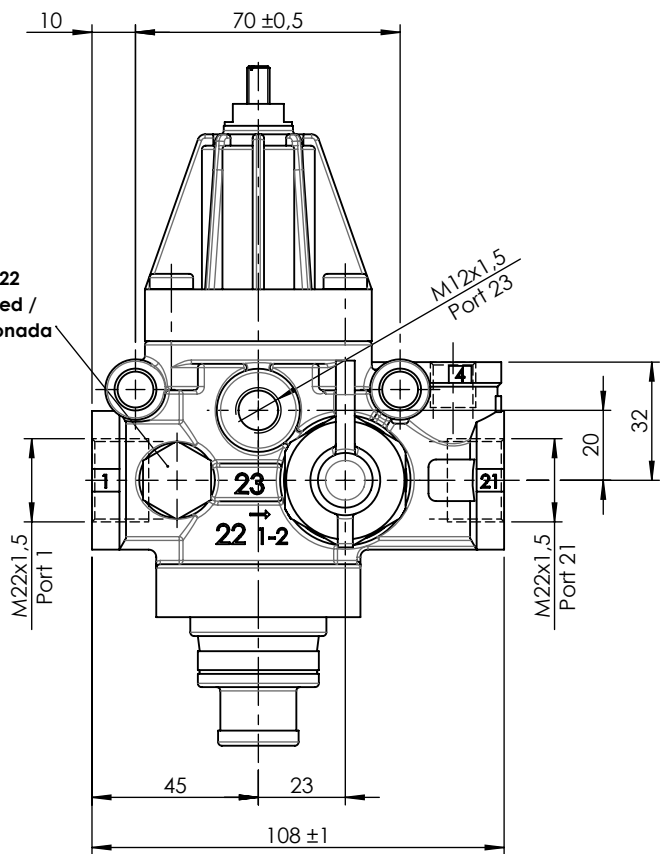

F	Modification	4				Drawn			
		3				05/08/14 A.U.			
		2				Checked			
		1				05/08/14 A.L.			
F	Comments	nº	Modified	Date	Reason	General Tolerance	Assembly	-	
							ISO 2768 c-K	Part name	Unloader valve
							Material	ID. Reference	2228231
							-	Scale: 1/2	
					-	Review: 0			