

1

2

3

4

A Technical sheet / Datos técnicos:

Part number adaptable to / Referencia adaptable a	4757150020
Braking pressure / Presión de frenos	max. 10 bar
Control pressure / Presión de control	max. 12 bar
Permissible medium / Medio de funcionamiento	Air / Aire
Operating temperature range / Rango de temperatura	-40 °C to / a +80 °C
Weight / Peso	2700 gr

B

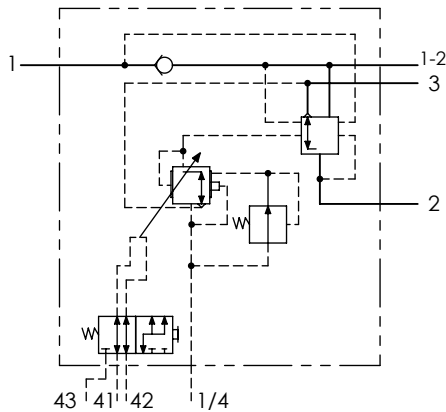

Pressure regulation / Regulación de presión

Position / Posición	P1	P1/4	P2
P41/42 = 0.6 bar	6.5 bar	6.5 bar	2.0 bar
P41/42 = 3.4 bar	6.5 bar	6.5 bar	6.2 bar

C

Port / Conexión	Function / Función	Thread / Rosca
1	Supply / Alimentación	M16x1.5
1-2	Reservoir supply / Reserva alimentación	M22x1.5
2	Delivery / Salida	2x M22x1.5, 4x M16x1.5
3	Exhaust / Escape	2x M6
1/4	Control / Pilotaje	M16x1.5
41	Suspension control / Pilotaje suspensión	M12x1.5
42	Suspension control / Pilotaje suspensión	M12x1.5
43	Test / Test	M16x1.5

D

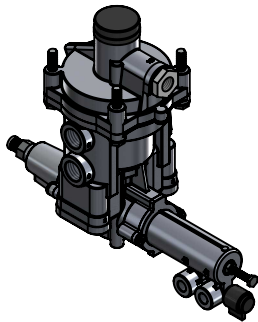

Purpose / Propósito: The automatically control braking force on the air brake chambers of vehicles with air suspended axles. Automatic control is dependent upon the air bag pressure which corresponds to the vehicle load. / El control automático de la fuerza de frenado en las cámaras de freno de aire comprimido de los vehículos con ejes dotados de suspensión neumática. El control automático depende de la presión del colchón neumático que corresponde a la carga del vehículo.

E

Installation requirements / Requisitos para la instalación: The valve must be installed vertically with the exhaust port (3) pointing downwards. Mounting is accomplished with four screws M8. / La válvula debe fijarse verticalmente con el escape (3) orientado hacia abajo. El montaje se realiza con cuatro tornillos M8.

F

Modification	4				Drawn		
	3				17/02/11 A.U.		
	2				Checked		
	1				17/02/11 A.L.		
Comments	nº	Modified	Date	Reason	General Tolerance	Assembly	-
					-	Part name	ALB
					-	ID. Reference	2220701
				-	Scale: -		Sheet 1/2
				-	Review: 0		

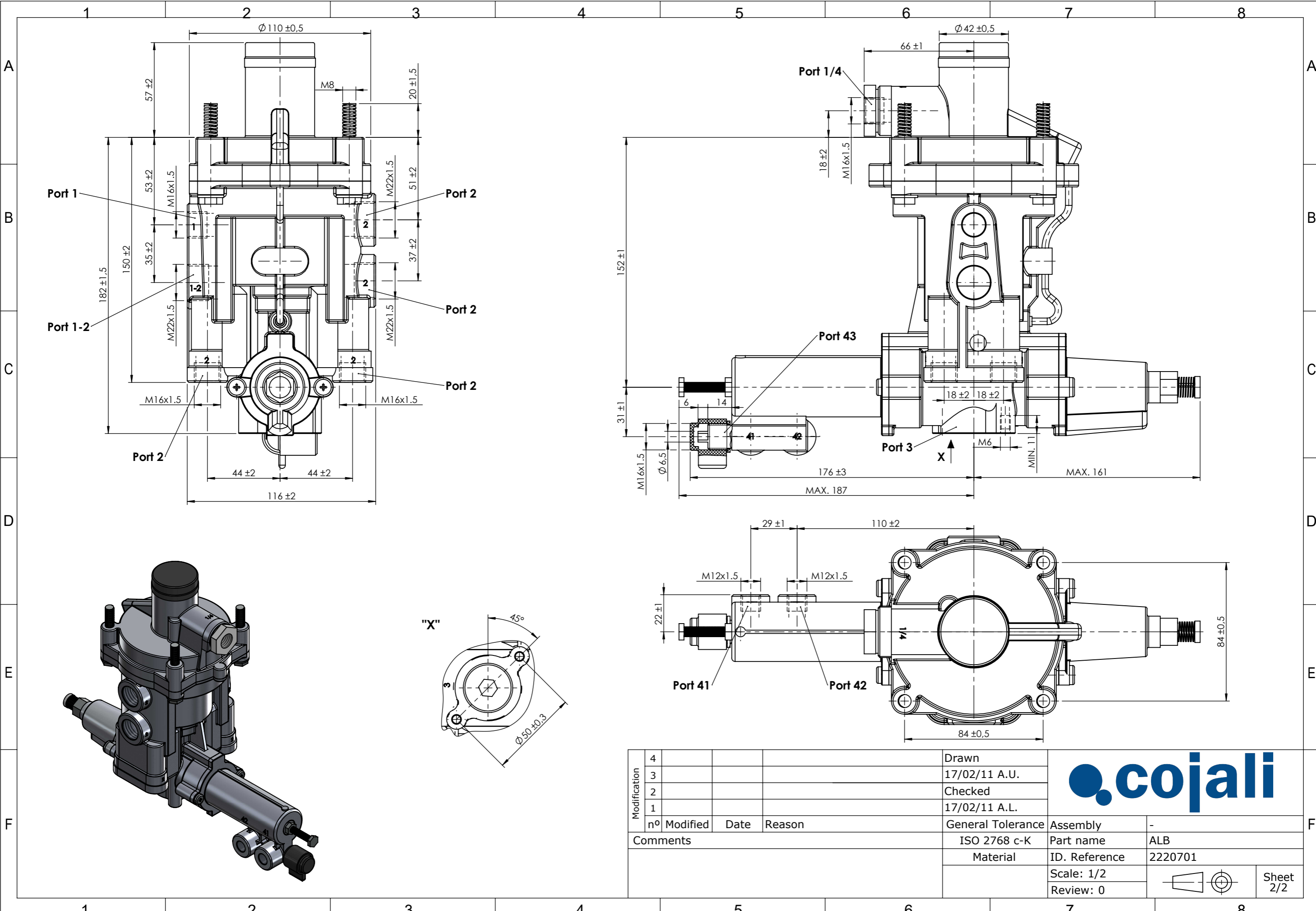

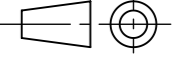
Modification	4			Drawn		
	3			17/02/11 A.U.		
	2			Checked		
	1			17/02/11 A.L.		
	n° Modified	Date	Reason	General Tolerance	Assembly	-
Comments				ISO 2768 c-K	Part name	ALB
				Material	ID. Reference	2220701
					Scale: 1/2	
					Review: 0	