

Technical sheet / Datos técnicos:

| | |
|--|--------------------|
| Part number adaptable to / Referencia adaptable a | 4757100330 |
| Operating pressure / Presión de trabajo | max. 10 bar |
| Actuation angle / Ángulo de actuación | -45° to / a +30° |
| Regulation index / Índice de regulación | 1 : 8 |
| Permissible medium / Medio de funcionamiento | Air / Aire |
| Operating temperature range / Rango de temperatura | -40°C to / a +80°C |
| Weight / Peso | 1700 gr |

Pressure regulation / Regulación de presión

| Angle / Ángulo | P1 | P4 | P2 |
|---------------------|---------|---------|---------|
| $\alpha = 0^\circ$ | 7.5 bar | 7.5 bar | 1.9 bar |
| $\alpha = 30^\circ$ | 7.5 bar | 7.5 bar | 7.5 bar |

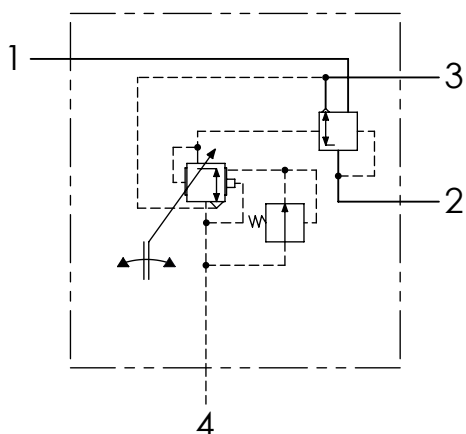

| Port / Conexión | Function / Función | Thread / Rosca |
|-----------------|-----------------------|----------------|
| 1 | Supply / Alimentación | M22x1.5 |
| 2 | Output / Salida | 2x M16x1.5 |
| 3 | Exhaust / Escape | - |
| 4 | Control / Pilotaje | M16x1.5 |

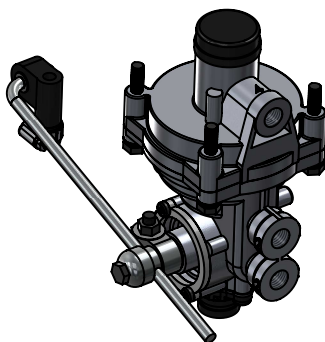

Purpose / Propósito: To automatically control braking effort on an axle in response to the suspension deflection caused by the vehicle load and to ensure rapid supply and exhaust for the brake actuators by means of the integral relay. / Controlar automáticamente el esfuerzo de frenada en un eje como respuesta a la desviación en la suspensión causada por la carga para asegurar el rápido suministro y escape de los actuadores de freno por medio del relé.

Installation requirements / Requisitos para la instalación: The valve must be installed vertically with the exhaust port (3) pointing downwards. At least 2 of 4 M8 mounting bolts should be used to attach the valve to the chassis. / La válvula debe montarse verticalmente con el escape (3) hacia abajo. La válvula se fijará al chasis con, al menos, 2 de los 4 tornillos M8.

| | | | | | | | | |
|--------------|----|----------|------|--------|-------------------|---------------|---------|-----------|
| Modification | 4 | | | | Drawn | | | |
| | 3 | | | | 20/07/18 A.I. | | | |
| | 2 | | | | Checked | | | |
| | 1 | | | | 20/07/18 A.I. | | | |
| | nº | Modified | Date | Reason | General Tolerance | Assembly | | |
| Comments | | | | | - | Part name | ALB | |
| | | | | | Material | ID. Reference | 2220355 | |
| | | | | | - | Scale: - | | Sheet 1/2 |
| | | | | | - | Review: 0 | | |

cojali

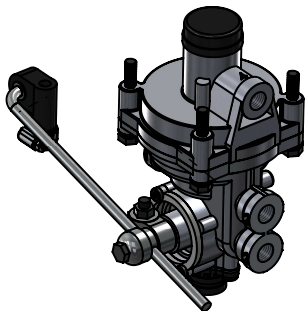
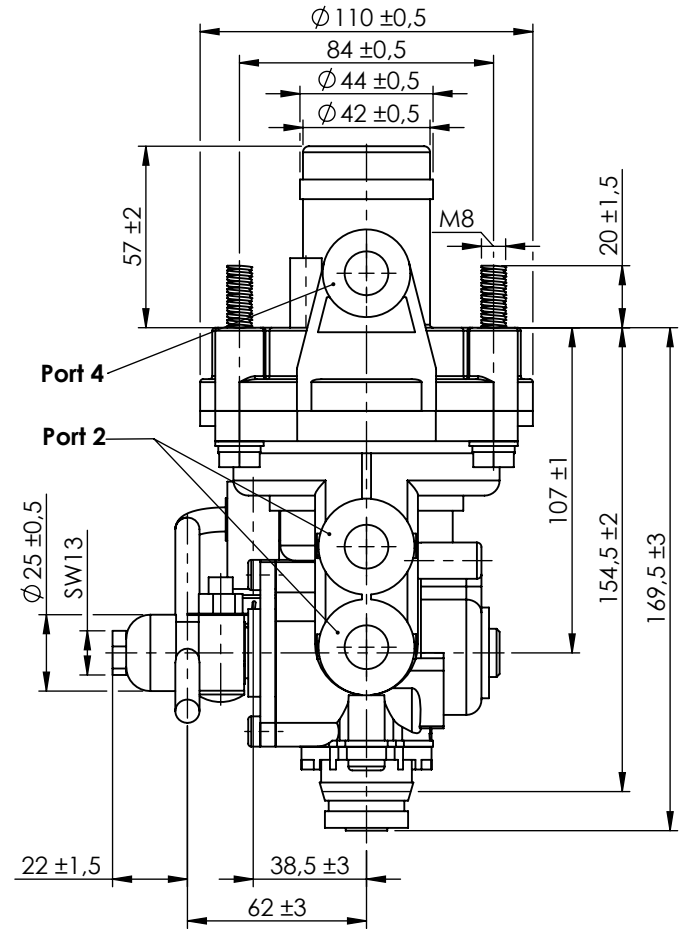
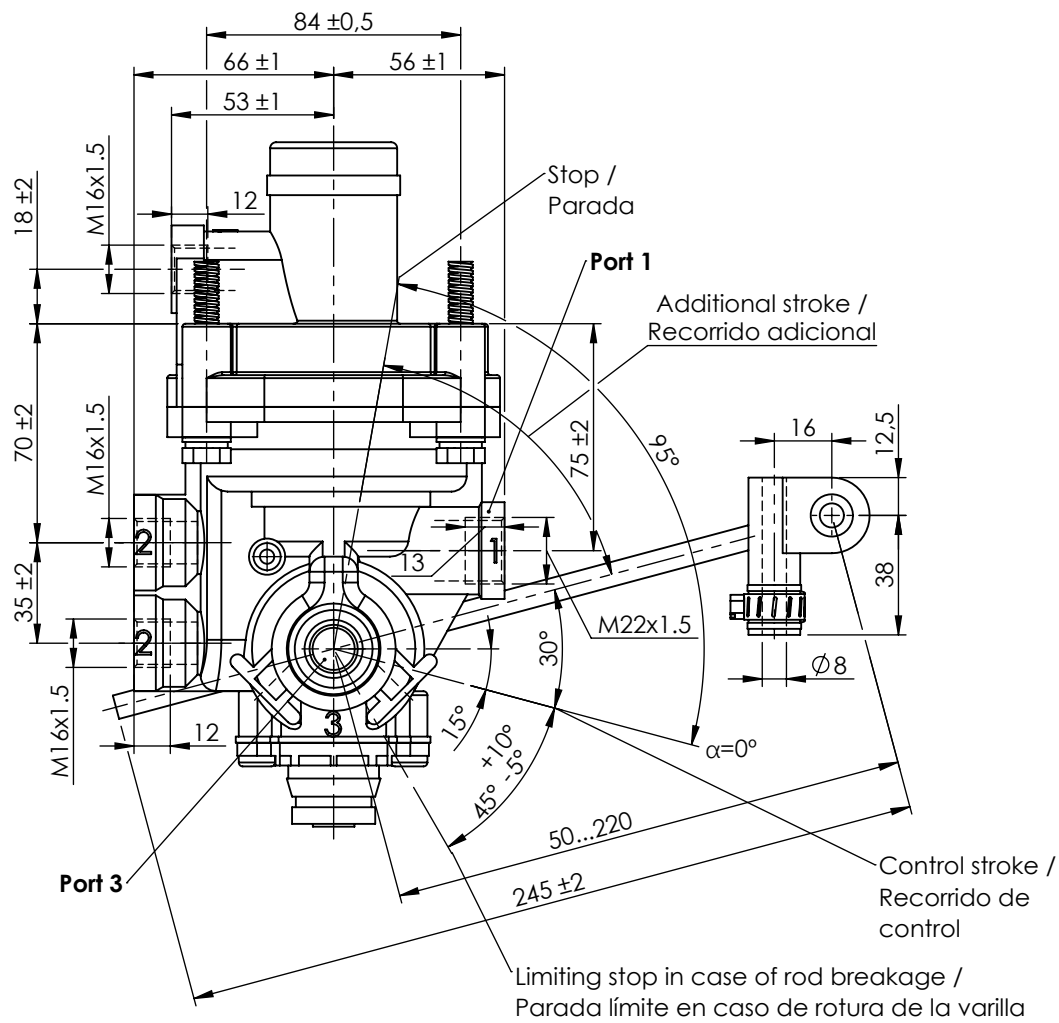

| | | | | | | | |
|--------------|----|----------|------|--------|-------------------|---------------|---------|
| Modification | 4 | | | | Drawn | | |
| | 3 | | | | 20/07/18 A.I. | | |
| | 2 | | | | Checked | | |
| | 1 | | | | 20/07/18 O.V. | | |
| | nº | Modified | Date | Reason | General Tolerance | | |
| Comments | | | | | Assembly | - | |
| | | | | | ISO 2768 c-K | Part name | ALB |
| | | | | | Material | ID. Reference | 2220355 |
| | | | | | | Scale: 2/5 | |
| | | | | | | Review: 0 | |



Sheet
2/2