

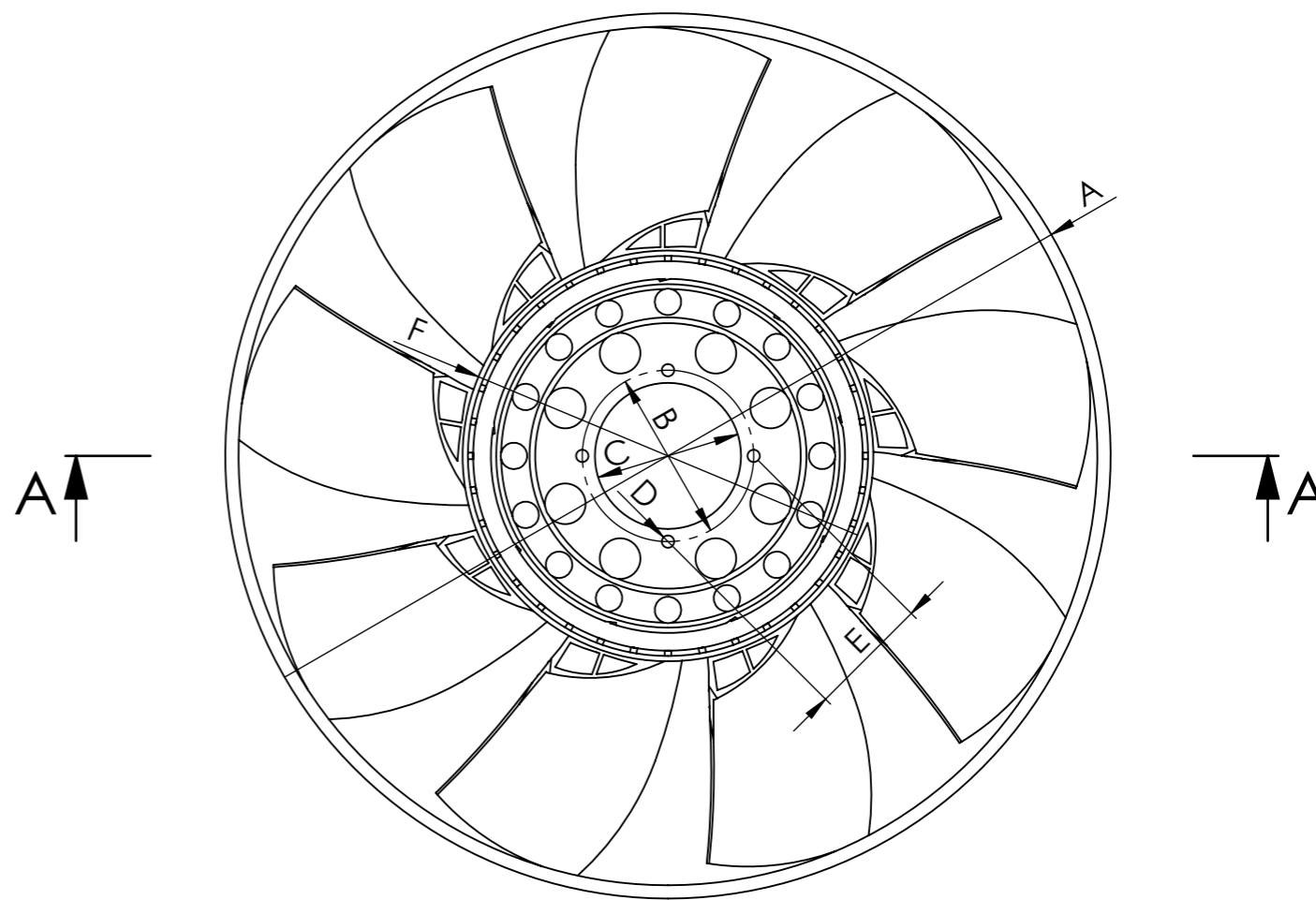

SECTION A-A

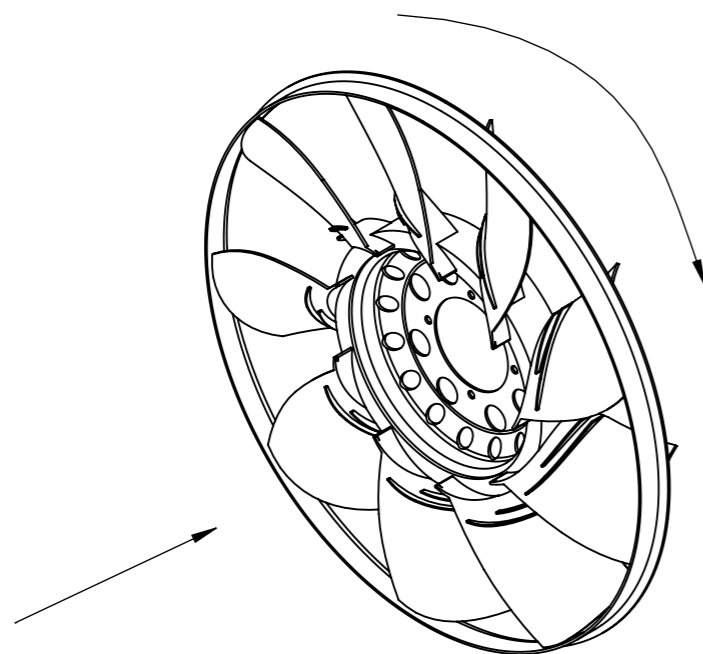

Dimensional values		FAN WHEEL			
		Ref.n°	Value	Ref.n°	Value
A	Ø 500 ± 3 mm	G	38,5 ± 3 mm		
B	Ø 96,8 mm	H	4,5 ± 3 mm		
C	Ø 82,5 +0,3 0 mm	I	61 ± 3 mm		
D	4x Ø 7 mm	J	Ø 490 ± 3 mm		
E	68,5 mm				
F	Ø 232 ± 3 mm				
Number of blades		9	Configuration		CW

Modification n°	Modified	Date	Reason	Comments	Drawn
					4
3					Checked
2					08/10/25 R.U.
1					

General Tolerance		ISO 2768 c-K		
Material				
Assembly Part name		Fan wheel		Technical sheet ID. Reference 8130600
Scale: 1/4				
Review: 0				Sheet 1/1 