

Technical sheet / Datos técnicos:

Part number adaptable to / Referencia adaptable a	22327063
Operating pressure / Presión de trabajo	8 bar
Permissible medium / Medio de funcionamiento	Air / Aire
Operating temperature range / Rango de temperatura	-40°C to / a +80°C
Weight / Peso	1800 gr

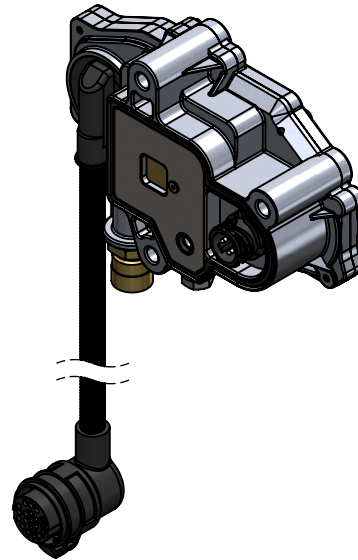
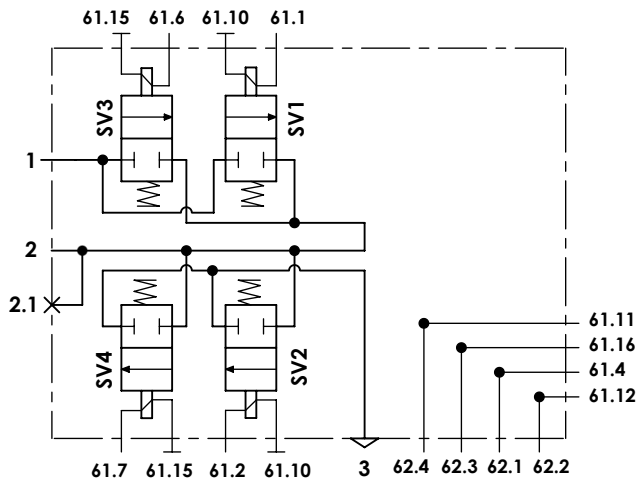

Port / Conexión	Function / Función	Thread / Rosca
1	Supply / Alimentación	M16x1.5 + Adaptor/Adaptador Ø12
2	Delivery / Salida	Ø7
2.1	Test connection / Conexión test	Closed / Taponada
3	Exhaust / Escape	-
61	Main connector / Conector principal	Kostal 09 4320 01
62	Secondary connector / Conector secundario	DIN 72585-A1-4

Purpose / Propósito: Optimize gear shifting for smooth and accurate transmission operation. / Optimizar el cambio de marchas para conseguir un funcionamiento suave y preciso de la transmisión.

Installation requirements / Requisitos para la instalación: The clutch module is fastened using three M8 screws. / El módulo de embrague es fijado usando tres tornillos M8.

Modification	4				Drawn			
	3				19/02/20 S.F.			
	2				Checked			
	1				19/02/20 D.M.			
	nº	Modified	Date	Reason	General Tolerance		Assembly	-
Comments					-	Part name	Clutch module	
					Material	ID. Reference	2880246	
					-	Scale: -		Sheet 1/2
					-	Review: 0		

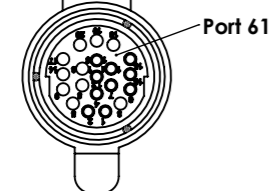
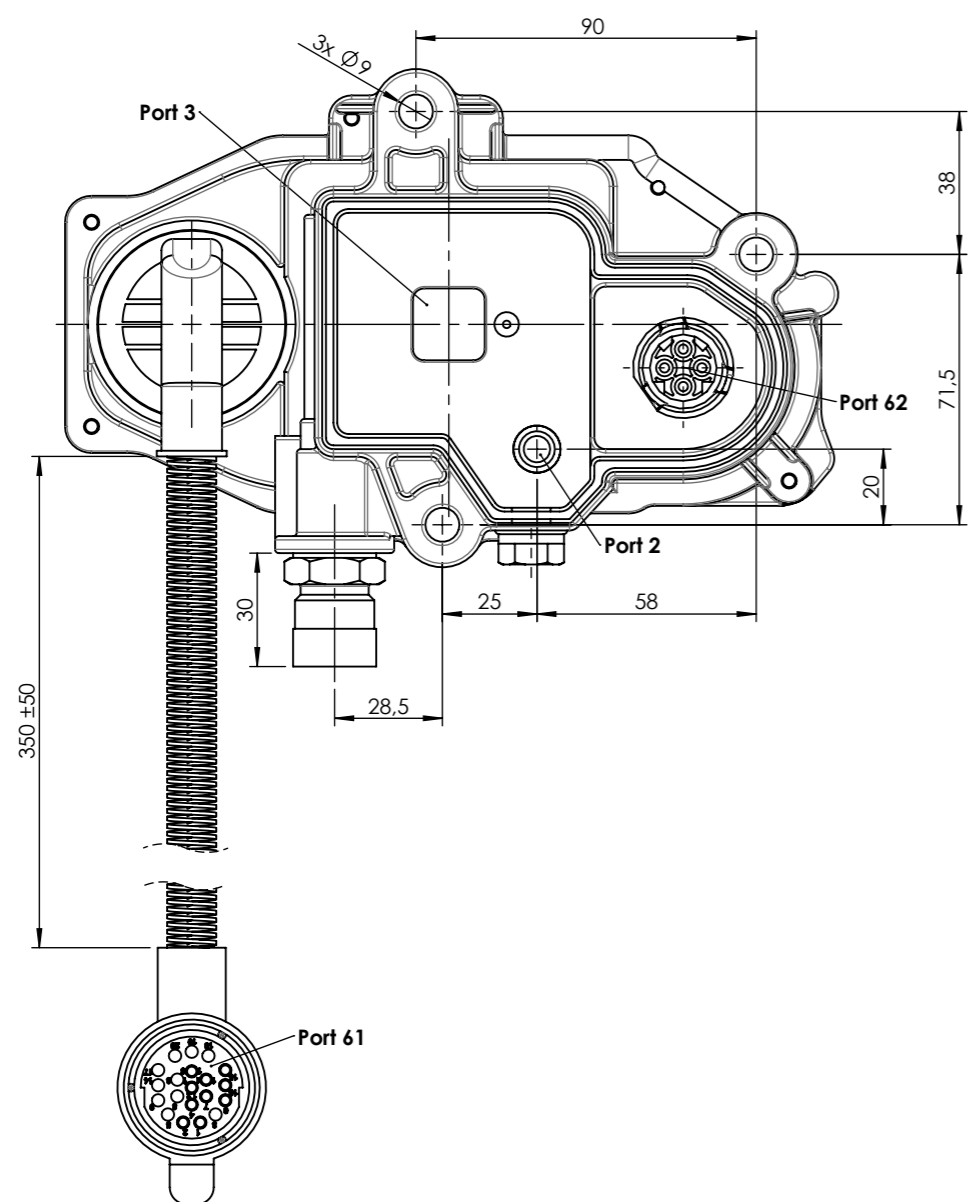
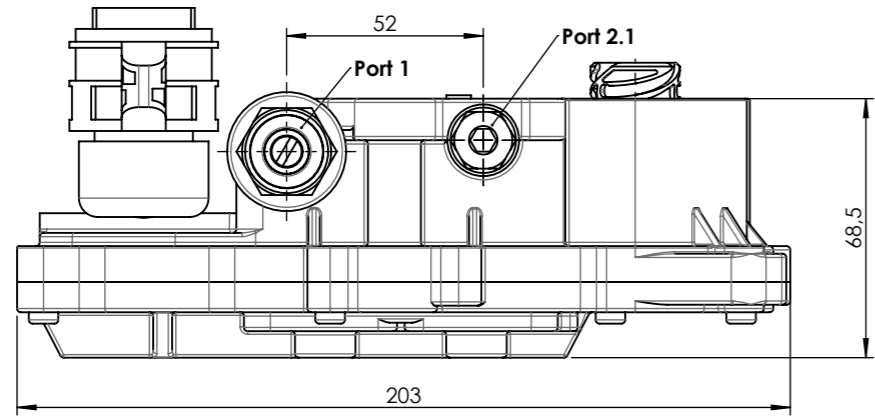

Pin	Function / Función
61.1	Inlet Low Airflow - Positive / Válvula de admisión lenta - Positivo
61.2	Exhaust Low Airflow - Positive / Válvula de escape lento - Positivo
61.4	Clutch Position Sensor - Positive / Sensor de posición del embrague - Positivo
61.6	Inlet High Airflow - Positive / Válvula de admisión rápida - Positivo
61.7	Exhaust High Airflow - Positive / Válvula de escape rápido - Positivo
61.10	Inlet & Exhaust Low Airflow - Ground / Válvulas de admisión y escape lentos - Masa
61.11	Clutch Position Sensor - Signal / Sensor de posición del embrague - Signal
61.12	Clutch Position Sensor - Ground / Sensor de posición del embrague - Masa
61.15	Inlet & Exhaust High Airflow - Ground / Válvulas de admisión y escape rápidos - Masa
61.16	Clutch Position Sensor - Signal / Sensor de posición del embrague - Signal

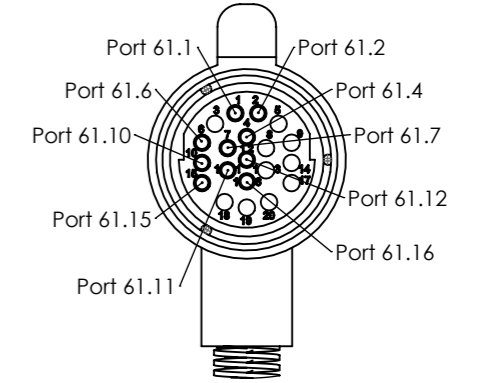

Port 61
Scale/Escala 2:3

Pin	Function / Función
62.1	Clutch Position Sensor - Positive / Sensor de posición de embrague - Positivo
62.2	Clutch Position Sensor - Ground / Sensor de posición del embrague - Masa
62.3	Clutch Position Sensor - Signal / Sensor de posición del embrague - Señal
62.4	Clutch Position Sensor - Signal / Sensor de posición del embrague - Señal

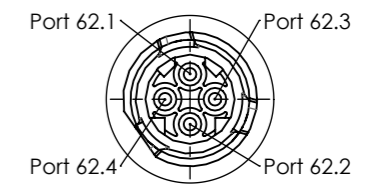

Port 62
Scale/Escala 2:3

Modification	4			Drawn		
	3			19/02/20 S.F.		
	2			Checked		
	1			19/02/20 D.M.		
	nº Modified	Date	Reason	General Tolerance	Assembly	
Comments				ISO 2768 c-K	Part name	-
				Material	ID. Reference	Clutch module
				-	Scale: 1/2	2880246
					Review: 0	
						Sheet 2/2