

Technical sheet / Datos técnicos:

Part number adaptable to / Referencia adaptable a	AC595B
Operating pressure / Presión de trabajo	max. 8.5 bar
Predominance / Predominancia	0.2 bar
Permissible medium / Medio de funcionamiento	Air / Aire
Operating temperature range / Rango de temperatura	-40 °C to / a +80 °C
Weight / Peso	2300 gr

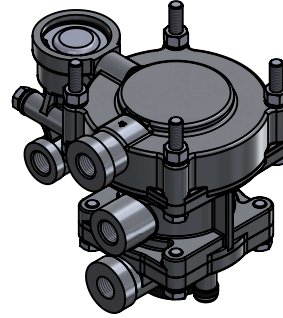

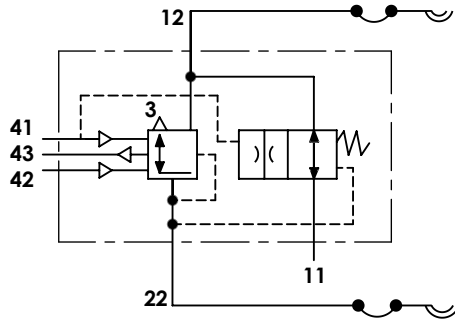

Port / Conexión	Function / Función	Thread / Rosca
11	Supply / Alimentación	M16x1.5
12	Trailer supply line / Línea de alimentación del trailer	M16x1.5
22	Trailer service line / Línea de pilotaje del trailer	M16x1.5
41	Service braking system (circuit 1) / Freno de servicio (circuito 1)	M16x1.5
42	Service braking system (circuit 2) / Freno de servicio (circuito 2)	M16x1.5
43	Spring brake cylinder / Cilindro del freno de muelle	M16x1.5
3	Exhaust / Escape	-

Purpose / Propósito: To transfer the braking demand between the truck and trailer ensuring a coordinated braking between both vehicles. This valve contains a service brake line and a parking brake line. In case of breakage of the brake line between both vehicles, an emergency function is enable to produce a throttling of air supply from the truck to the trailer ensuring a maintenance of pressure of the brake circuits of towing vehicle. / Transferir la demanda de frenado entre el camión y el remolque asegurando una frenada coordinada entre ambos vehículos. Dispone de líneas de servicio y freno de estacionamiento. En caso de rotura de la línea de freno entre ambos vehículos se acciona una función de emergencia en la que se produce un estrangulamiento de aire desde la alimentación de la cabeza tractora hacia el remolque asegurando un mantenimiento de la presión en los circuitos de freno de la cabeza tractora.

Installation requirements / Requisitos para la instalación: The valve must be installed so that the exhaust port faces downwards. The valve should be mounted with two of four M8 mounting bolts. / La válvula debe instalarse para que el escape señale hacia abajo. La válvula debe montarse con dos de los cuatro pernos de montaje M8.

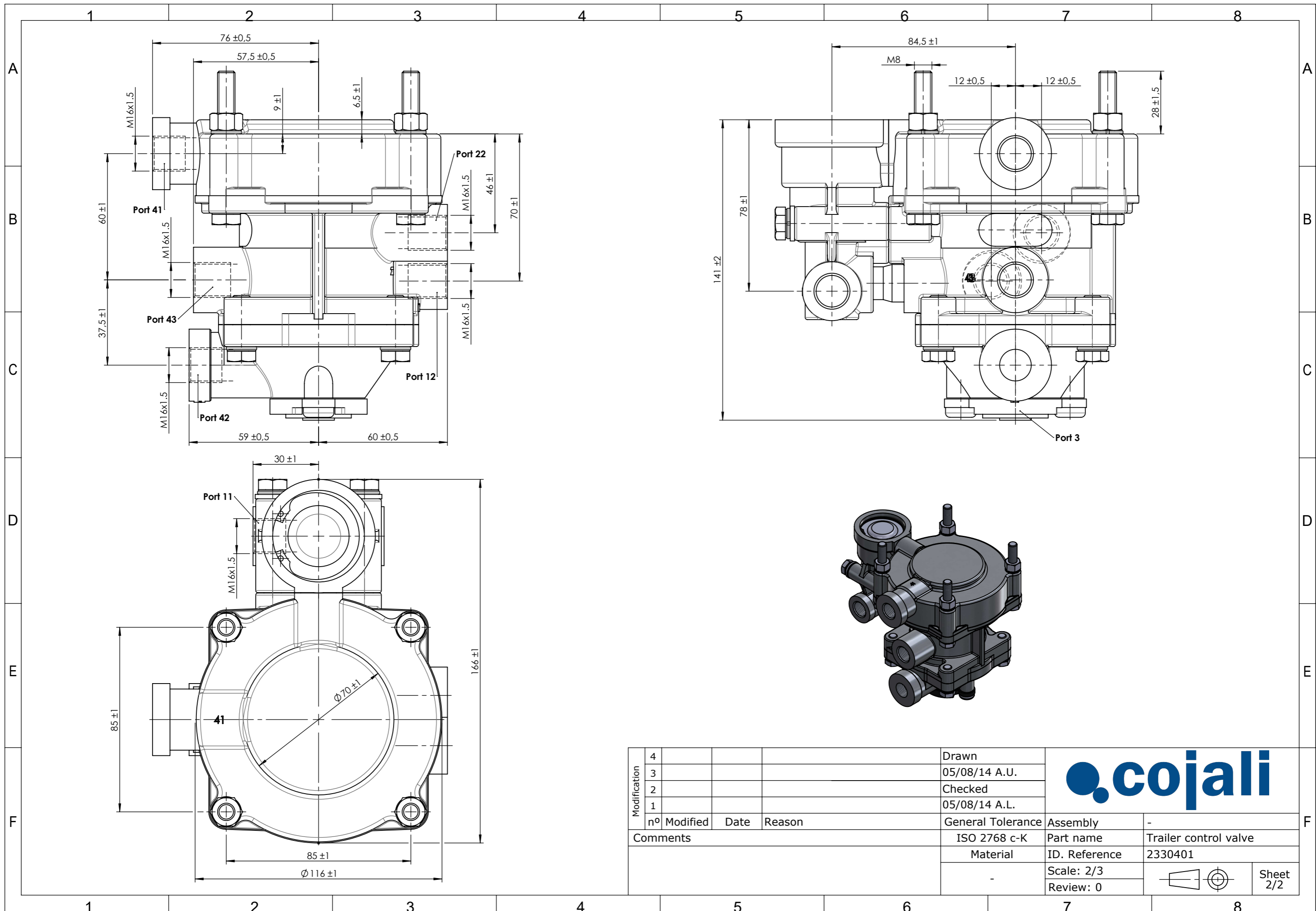
Modification	4				Drawn		
	3				05/08/14 A.U.		
	2				Checked		
	1				05/08/14 A.L.		
F	nº	Modified	Date	Reason	General Tolerance	Assembly	-
	Comments				-	Part name	Trailer control valve
					Material	ID. Reference	2330401
				-	Scale: -		Sheet 1/2
				-	Review: 0		



Modification	4			Drawn		
	3			05/08/14 A.U.		
	2			Checked		
	1			05/08/14 A.L.		
	nº Modified	Date	Reason	General Tolerance	Assembly	-
Comments				ISO 2768 c-K	Part name	Trailer control valve
				Material	ID. Reference	2330401
				-	Scale: 2/3	
					Review: 0	