

Technical sheet / Datos técnicos:

Part number adaptable to / Referencia adaptable a	AE4800
Operating pressure / Presión de trabajo	max. 13 bar
Permissible medium / Medio de funcionamiento	Air / Aire
Operating temperature range / Rango de temperatura	-40°C to / a +80°C
Weight / Peso	1700 gr

Port / Conexión	Function / Función	Thread / Rosca
1	Supply / Alimentación	M16x1,5
21	Delivery / Salida	M22x1,5 VOSS
22	Delivery / Salida	M22x1,5 VOSS
23	Delivery / Salida	M22x1,5 VOSS
24	Delivery / Salida	M22x1,5 VOSS
25	Delivery / Salida	M22x1,5 VOSS
26	Delivery / Salida	M22x1,5 VOSS
27	Delivery / Salida	M12x1,5
28	Delivery / Salida	M12x1,5
3	Exhaust / Escape	-
6	Electric connection / Conexión eléctrica	Bayonet DIN 72585 A1-6

Circuit / Circuito	1	2	3	4
Port / Conexión	21	22	23 25 27	24 26 28
Opening pressure / Presión de apertura (bar)	9,0 ⁰ _{-0,3}		7,5 ⁰ _{-0,3}	
Closing pressure dynamic / Presión de cierre dinámica (bar)	> 6,0		> 6,0	
Pressure limiting / Presión de limitación (bar)	-		8,5 ⁰ _{-0,4}	

Circuit / Circuito	1			2		
Contact / Contacto	6.2	6.3	6.4	6.5	6.6	6.7
Function / Función	Output / Salida	+5 V	GND	Output / Salida	+5 V	GND

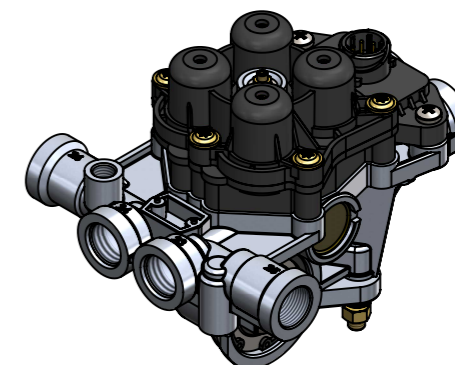
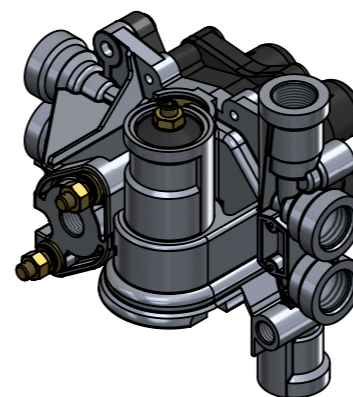
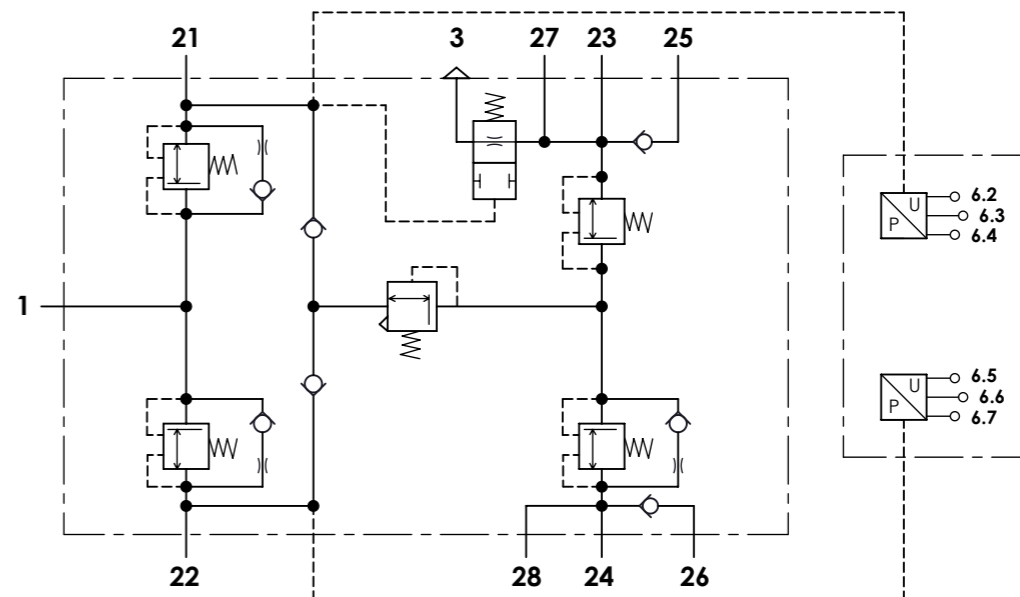

Purpose / Propósito:



To distribute clean and dry air from the air dryer to different pneumatic circuits. Ensure pressure in brake circuits in case of leaks or breakage in any circuit. It includes a sensor to measure the supply pressures of service brake circuits. / Distribuir el aire limpio y seco proveniente del secador a los diferentes circuitos neumáticos. Asegurar la presión en los circuitos de freno en caso de fuga o rotura en cualquier circuito. Incorpora un sensor para medir las presiones de alimentación de los circuitos de freno de servicio.

Installation requirements / Requisitos para la instalación:

Mounting is accomplished by using two mounting bolts M8. / El montaje se realiza mediante dos pernos M8.

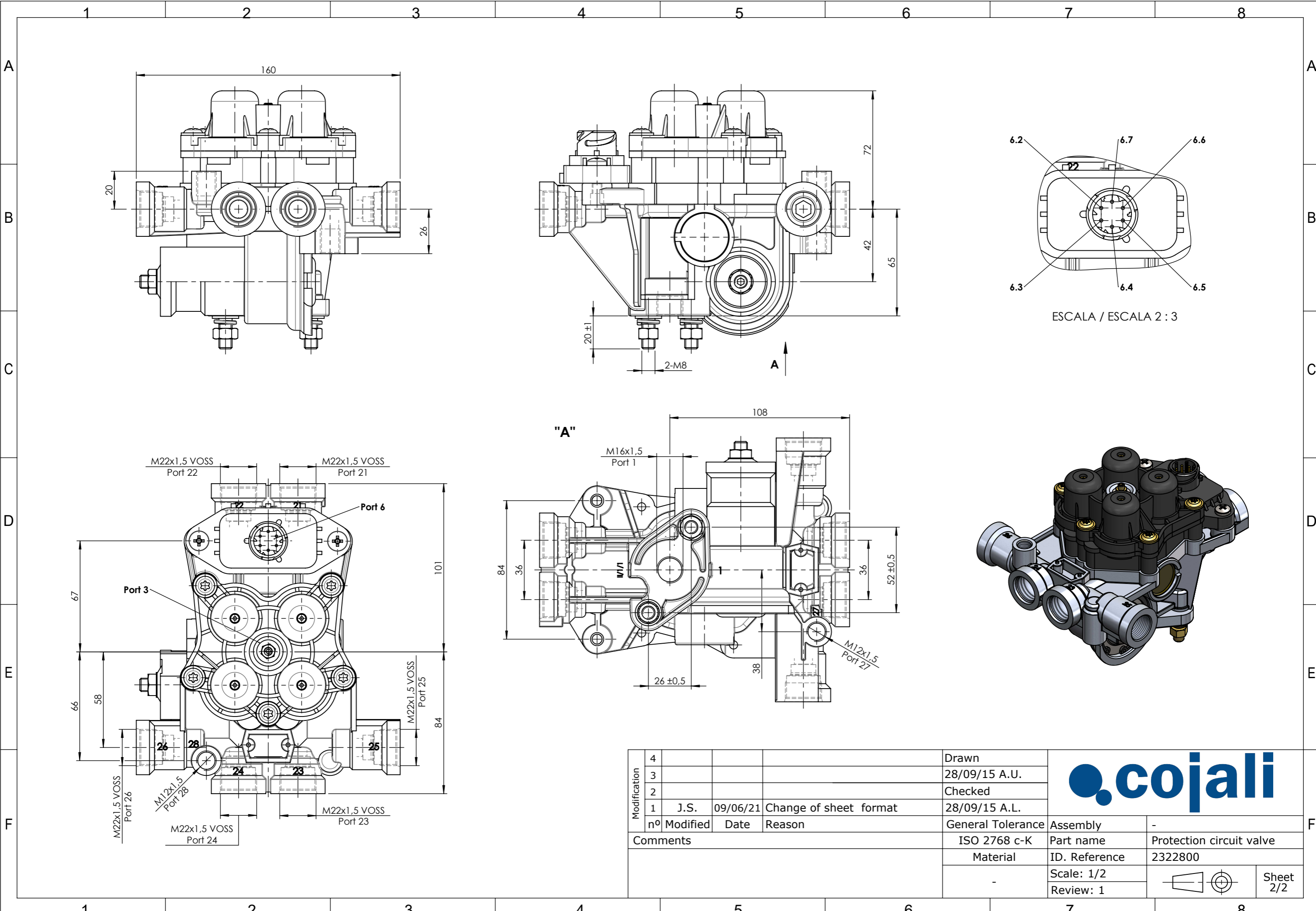
Modification	4			Drawn	
	3			28/09/15 A.U.	
	2			Checked	
	1	J.S.	09/06/21	Change of sheet format	
	nº	Modified	Date	Reason	
Comments				General Tolerance	Assembly
				-	Part name
				Material	ID. Reference
				-	2322800
				Scale: -	
				Review: 1	
					Sheet 1/2



Modification	4			Drawn		
	3			28/09/15 A.U.		
	2			Checked		
	1	J.S.	09/06/21	Change of sheet format		28/09/15 A.L.
	nº Modified	Date	Reason	General Tolerance	Assembly	
Comments				ISO 2768 c-K	Part name	-
				Material	ID. Reference	2322800
				-	Scale: 1/2	
				Review: 1	Sheet 2/2	