

1

2

3

4

A

Technical sheet / Datos técnicos:

A

Part number adaptable to / Referencia adaptable a	K015676N00
Working pressure / Presión de trabajo	max 10.2 bar
Type of current / Tipo de corriente	Direct current/ Corriente continua
Voltage / Voltaje	24 V
Nominal current / Corriente nominal	1.65 A
Permissible medium / Medio de funcionamiento	Air / Aire
Operating temperature range / Rango de temperatura	-40°C to / a +80°C
Weight / Peso	665 gr

B

B

C

C

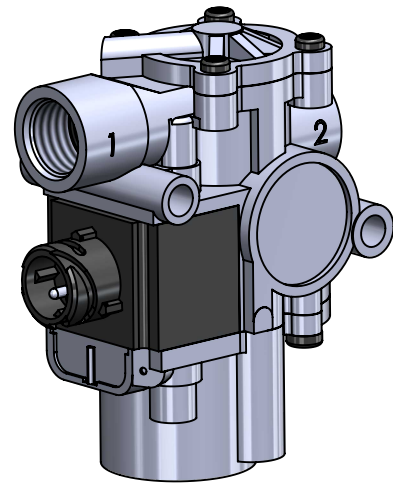
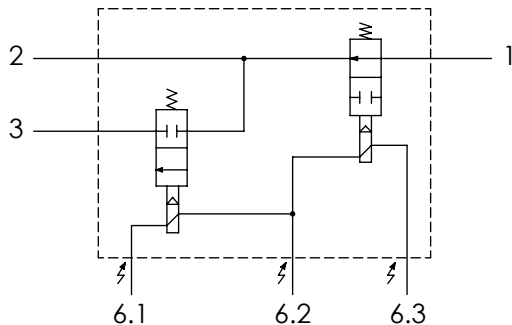

D

D

Port / Conexión	Function / Función	Thread / Rosca
1	Supply / Alimentación	M22x1.5 VOSS
2	Delivery / Salida	M22x1.5 VOSS
3	Exhaust / Escape	-
6	Connector / Conector	DIN 72585-A1-3.1-Sn/K1

Purpose / Propósito: Increase, reduce or maintain the pressure in the brake cylinders during a braking process according to the regulation of the ABS electronic control unit. / Aumentar, reducir o mantener la presión en los cilindros de freno durante un proceso de frenado según la regulación de la unidad de control electrónico ABS.

E

E

Installation requirements / Requisitos para la instalación: To install the modulator with the exhaust port facing downwards. The modulator must be installed using two screws M8. / Instalar el modulador con el escape orientado hacia abajo. El modulador debe ser instalado utilizando dos tornillos M8.

F

F

Modification	4				Drawn		
	3				26/08/13 A.U.		
	2				Checked		
	1				26/08/13 A.L.		
	nº	Modified	Date	Reason	General Tolerance		Assembly
Comments					-	Part name	ABS modulator
					Material	ID. Reference	2309209
					-	Scale: -	
					-	Review: 0	

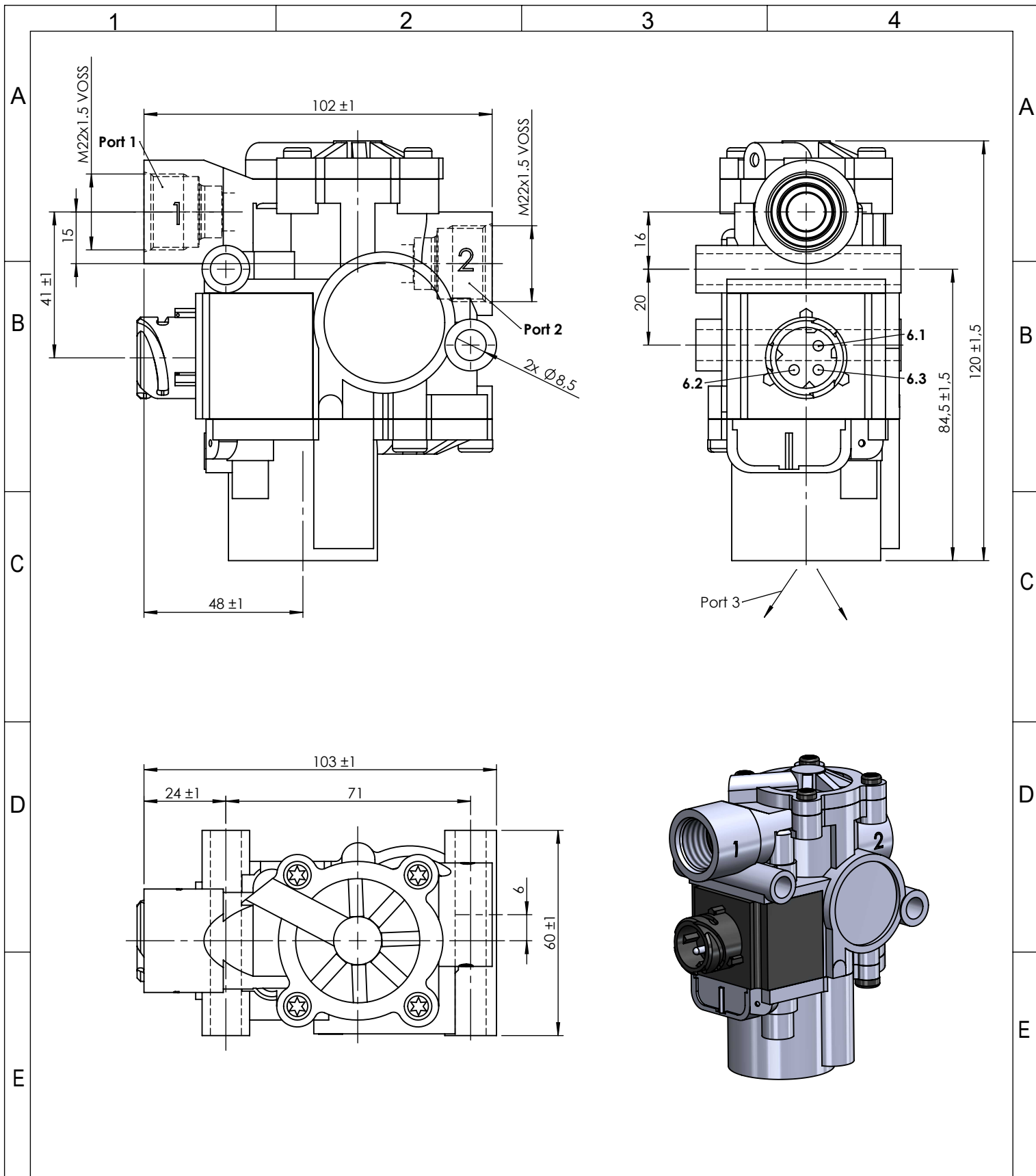

F	Modification	4				Drawn		F
		3				26/08/13 A.U.		
		2				Checked		
		1				26/08/13 A.L.		
	n°	Modified	Date	Reason	General Tolerance	Assembly		
Comments					ISO 2768 c-K	Part name	ABS modulator	
					Material	ID. Reference	2309209	
					-	Scale: 2/3		Sheet 2/2
					-	Review: 0		