

1

2





3

4

Technical sheet /Datos técnicos:

Part number adaptable to / Referencia adaptable a	4756040120
Operating pressure / Presión de trabajo	max. 10 bar
Permissible medium / Medio de funcionamiento	Air / Aire
Operating temperature range / Rango de temperatura	-40°C to / a +80°C
Weight / Peso	650 gr

Pressure regulation / Regulación de presión

Symbol / Símbolo	Description / Descripción	Range of adjustment / Rango de ajuste (bar)	Adjusted to / Ajustado a (bar)
	Release position / Posición de reposo		
	Empty position / Posición vacío	0.8 ... 2.2	1.6 (-0.2)
	Half load position / Posición media carga	2.8 ... 3.7	3.4 (-0.2)
	Full load position / Posición carga completa		

Port / Conexión	Function / Función	Thread / Rosca
1	Supply / Alimentación	M22x1.5
2	Output / Salida	M22x1.5

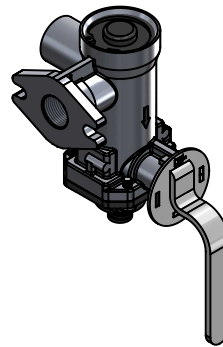
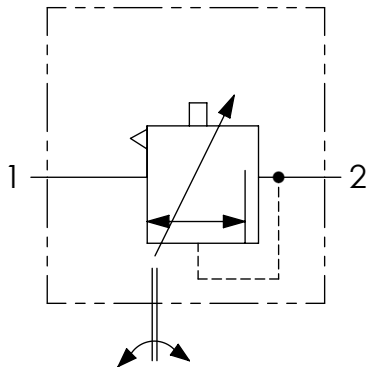

Purpose / Propósito: To regulate the pressure in the brake line of a trailer in relation to the load carrying. / Regular la presión en la línea de frenos de un trailer en relación a la carga que lleva.

Installation requirements / Requisitos para la instalación: The control valve must be attached directly to the relay emergency with the sealing. / La válvula de regulación debe unirse directamente a la válvula de emergencia relé con el anillo de cierre.

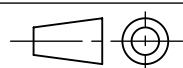
Modification	4				Drawn		
	3				17/02/11 A.U.		
	2				Checked		
	1				17/02/11 A.L.		
	nº	Modified	Date	Reason	General Tolerance		Assembly
Comments					-	Part name	ALB
					Material	ID. Reference	2225102
					-	Scale: -	
					-	Review: 0	

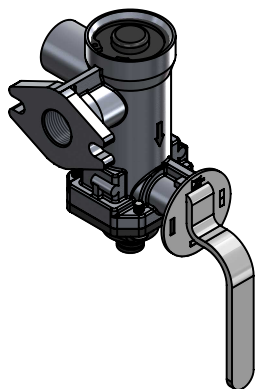
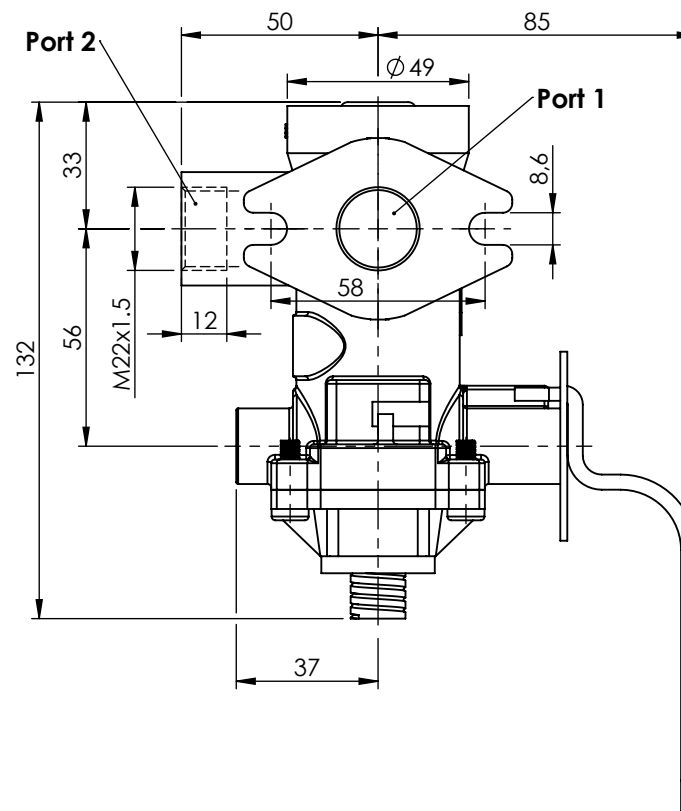
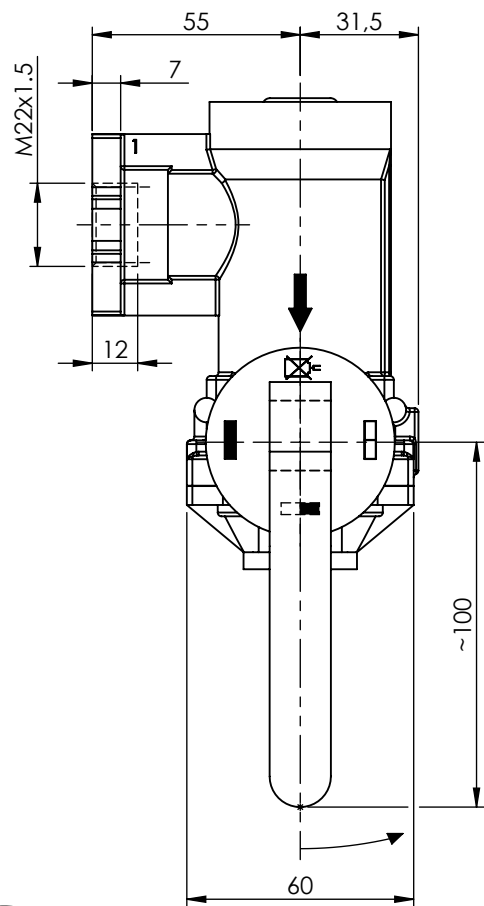

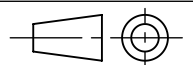
Modification	4				Drawn		
	3				17/02/11 A.U.		
	2				Checked		
	1				17/02/11 A.L.		
	nº	Modified	Date	Reason	General Tolerance	Assembly	
Comments					ISO 2768 c-K	Part name	ALB
					Material	ID. Reference	2225102
						Scale: 1/2	
						Review: 0	

Sheet
2/2