

1

2

3

4

A

Technical sheet / Datos técnicos:

A

Part number adaptable to / Referencia adaptable a	9617231250
Operating pressure / Presión de trabajo	max. 11 bar
Actuation angle / Ángulo de accionamiento	73°
Permissible medium / Medio de funcionamiento	Air / Aire
Operating temperature range / Rango de temperatura	-40°C to / a +80°C
Weight / Peso	800 gr

B

B

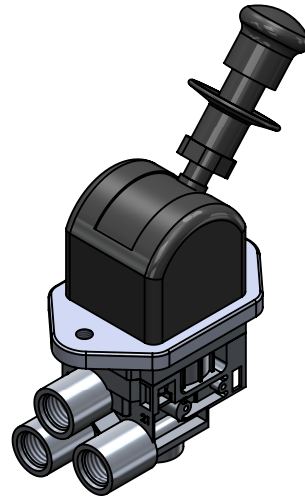
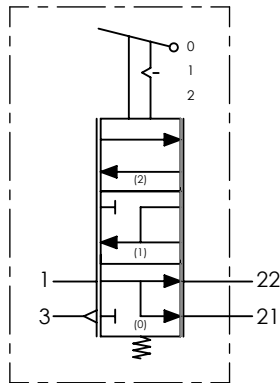

C

C

D

D

Port / Conexión	Function / Función	Thread / Rosca
1	Supply / Alimentación	M16x1,5 VOSS
21	Delivery to relay valve / Salida a válvula relé	M16x1,5 VOSS
22	Delivery to trailer control valve/ Salida a válvula control remolque	M16x1,5 VOSS
3	Exhaust / Escape	-

E

E

Purpose / Propósito: Parking braking actuation due to pressure release of spring brakes actuators. / Accionamiento del freno de estacionamiento gracias al alivio de la presión en las cámaras de muelle de los actuadores de freno.

Installation requirements / Requisitos para la instalación: The valve is fastened using two screws M8. / La válvula es fijada usando dos tornillos M8.

F

F

Modification	4				Drawn		
	3				18/12/14 A.U.		
	2				Checked		
	1				18/12/14 A.L.		
nº	Modified	Date	Reason	General Tolerance	Assembly	-	
Comments					-	Part name	Hand brake valve
					Material	ID. Reference	2224359
					-	Scale: -	
					-	Review: 0	

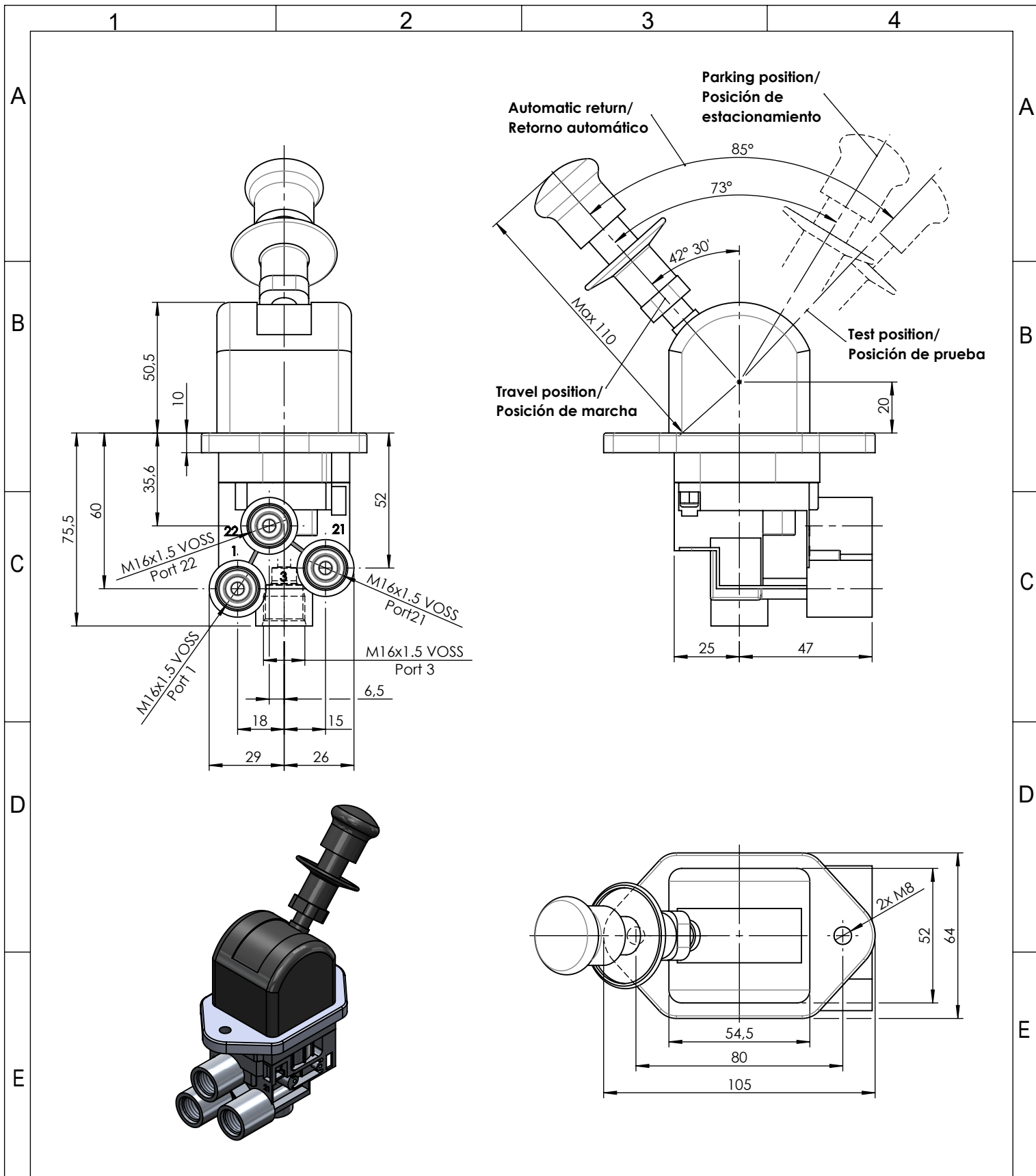

F	Modification				Drawn		F	
					18/12/14 A.U.			
					Checked			
					18/12/14 A.L.			
	nº	Modified	Date	Reason	General Tolerance			Assembly
Comments					ISO 2768 c-K	Part name	Hand brake valve	
					Material	ID. Reference	2224359	
					-	Scale: 1/2		Sheet 2/2
					-	Review: 0		