

1

2

3

4

A

Technical sheet / Datos técnicos:

Part number adaptable to / Referencia adaptable a	4520021320
Working pressure / Presión de trabajo	max 10 bar
Lever actuation / Palanca de accionamiento	90° (two ways / dos vías)
Permissible medium / Medio de funcionamiento	Air / Aire
Operating temperature range / Rango de temperatura	-40°C to / a +80°C
Weight / Peso	380 gr

B

C

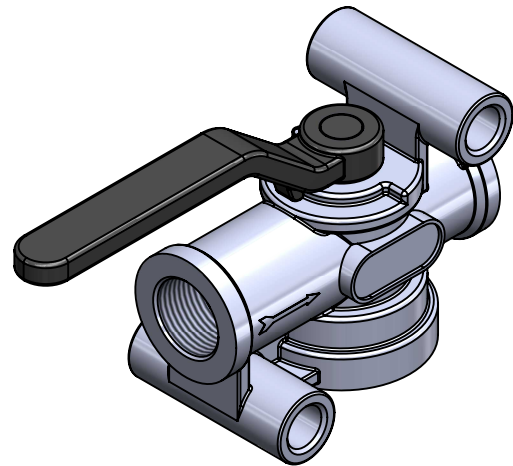
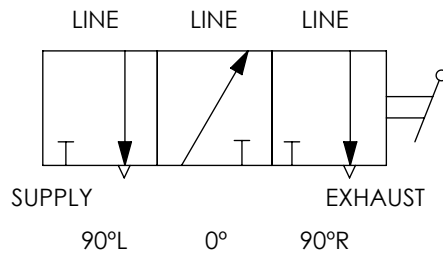

D

Port / Conexión	Function / Función	Thread / Rosca
1	Supply / Alimentación	M22x1.5
2	Delivery / Salida	M22x1.5

E

Purpose / Propósito: To close the compressed air flow and to depressurize the part of the circuit located after the valve. / Cerrar el paso de aire comprimido y despresurizar la parte del circuito situada a continuación de la válvula.

Installation requirements / Requisitos para la instalación: The valve must be installed using two screws M8. Take into account the direction of the flow indicated by the arrow on the housing. / La válvula debe ser instalada utilizando dos tornillos M8. Tener en cuenta la dirección del flujo indicada por la flecha que hay en la superficie de la válvula.

F

Modification	4				Drawn		
	3				22/09/14 A.U.		
	2				Checked		
	1				22/09/14 A.L.		
	nº	Modified	Date	Reason	General Tolerance		Assembly
Comments					-	Part name	Air valve platform
					Material	ID. Reference	2211102
					-	Scale: -	
					-	Review: 0	

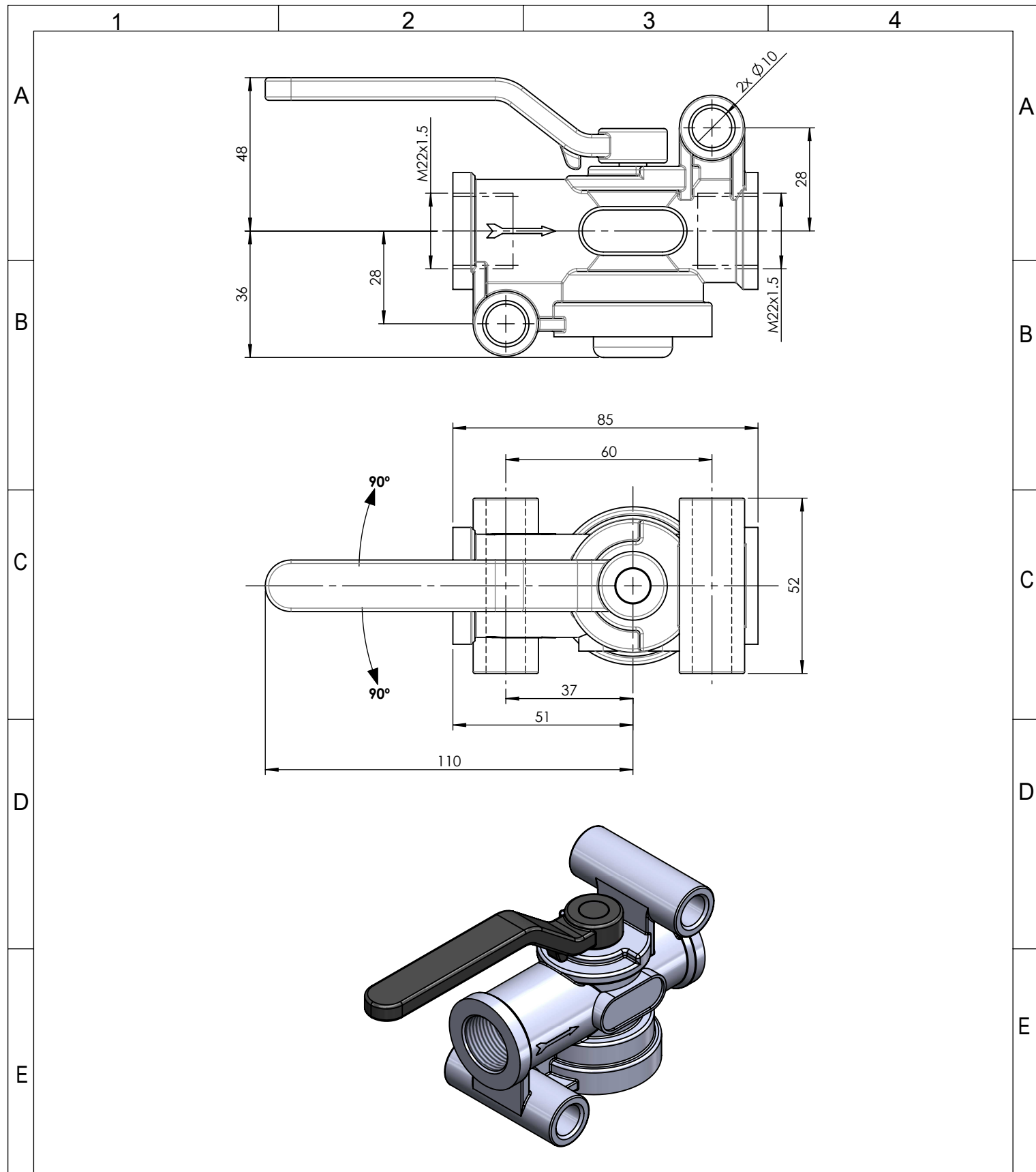

F	Modification					Drawn		F
	4					22/09/14 A.U.		
	3					Checked		
	2					22/09/14 A.L.		
	1							
n°	Modified	Date	Reason	General Tolerance	Assembly	-		
Comments					ISO 2768 c-K	Part name	Air valve platform	
					Material	ID. Reference	2211102	
					-	Scale: 2/3		Sheet 2/2
					-	Review: 0		
PG/18/02 rev.1 1					2	3	4	